



**SARDAR VALLABHBHAI PATEL  
UNIVERSITY OF AGRICULTURE & TECHNOLOGY  
MEERUT-250110**

**E-Bid Document**

*For*

**Tender for Establishment of IISR Model Jaggery Unit at KVK  
Hastinapur (Meerut) and KVK Muzaffarnagar-II**

**Under the R.K.V.Y. Project**

**Tender No: 03/SVP/2021-22**

**INDEX**

<b>S. No.</b>	<b>Description</b>	<b>Page No.</b>
1.	Important Dates and Fee detail	2
2.	e-Tender Terms and Conditions	3-8
3.	Detailed Status of the Firm(Technical Bid)	09-10
4.	Terms and conditions for the tender	11
5.	Self declaration	12
6.	Detail of the work for both KVK	13
7.	Equipment Technical specification sheet	14-22
8.	Layout plan of the Jaggery Plant	23-25
9.	General Instructions	26-29
10.	Performa for client list	30
11.	Mandate form for e-Payment	31
12.	Memorandum of Agreement	32-33

Note: The tenderer **should sign at each page of the tender and all its Annexure**. NO PAGE SHOULD BE REMOVED /DETACHED FROM THE TENDER DOCUMENT and all the TENDER DOCUMENT should be uploaded.



## **For the Visiting supplier 's of this e-Bid Document**

The Contractors/Firm/Bidders who are interested to participate in e-Bid are requested to get them registered at <https://etender.up.nic.in>.

The other important information is being mentioned below at a glance for the ease of e-Bid:-

Date of Inviting bid	:	14-09-2021
Bid closing date & Time	:	08-10-2021 at 10:00 AM
Date & time of opening bid	:	08-10-2021 at 12:00 Noon
Cost of bid document/ e-Bid processing fee	:	Rs. 1500.00 (Through RTGS/NEFT)
Earnest money	:	Rs. 70,500/= (Through RTGS/NEFT)
		EMD Exemption not allowed
Validity period	:	90 Days
Estimated cost of the work	:	Rs 70.00 lakh
Pre Bid	:	28-09-2021 at 11:00 AM

Earnest Money and tender processing fee paid only online by the way of RTGS/NEFT

Name of Bank	:	State Bank of India
Account Name	:	e-Tender
Name of Branch	:	SVBP University of Agriculture & Technology, Modipuram Meerut
Account No	:	39740364864
IFSC Code No	:	SBIN0010653

The Bidder will ensure to deposit e-bid processing fee and earnest money amount separately in the above mentioned account. The details of transaction must be provided in technical bid uploaded. Technical & Financial bid must be filled (**with page number on each page of uploaded file**) and uploaded by tenderers on <http://etender.up.nic.in> before the closing date and time, the failure of following instructions may cause the rejection of the e-Bid.

# **INSTRUCTIONS TO BIDDERS (ITB)**

## **(A) THE BID DOCUMENT**

### **1) Cost of Bid Document/ e-Bid Processing Fee**

- i) The bidder shall bear all costs associated with the preparation and submission of its e-Bid. Sardar Vallabhbhai Patel University of Agriculture & Technology Meerut hereinafter referred to as "SVPUA&T MEERUT", will in no case be responsible or liable for these costs, regardless of the conduct or outcome of the e-Bid process.
- ii) This bid document is available on the web site <http://etender.up.nic.in> to enable the bidders to view, download the e-Bid document and submit e-Bids online up to the last date and time mentioned in e-Bid notice / e-bid document against this e-Bid. The bidders shall have to pay cost of bid document / e-Bid processing fee as per eTender Invitation Notice through NEFT/ RTGS only This cost of bid document/ e-Bid processing fee will be non-refundable. Bid without cost of bid document/ e-Bid processing fee will not be accepted.

### **2) Contents of e-Bid Document**

- i) The scope of work, e-Bid procedure and contract terms and conditions are prescribed in the e-Bid document. The e-Bid document includes:
  - (1) Invitation for e-Bid
  - (2) Section I : Instructions to Bidders;
  - (3) Section II : Conditions of Contract;
  - (4) Section III : Technical e-Bid (Applicable only for Works as mentioned in e-Bid Notice);
  - (5) Section IV : Financial e-Bid;
- ii) The bidder is expected to examine all instructions, forms, terms and specifications in the e-Bid document. Failure to furnish all information required as per the e-Bid document or submission of e-Bid not responsive to the e-Bid document in every respect will be at the bidder's risk and may result in rejection of the said e-Bid.

### **3) Amendment of e-Bid Document**

- i) At any time prior to the deadline for submission of e-Bid, SVPUA&T, MEERUT may, for any reason, whether at its own initiative or in response to a clarification requested by a prospective bidder, modify the e-Bid document by amendments. Such amendments shall be uploaded on the e-Procurement website <http://etender.up.nic.in> through corrigendum and shall form an integral part of e-Bid document. The relevant clauses of the e-Bid document shall be treated as amended accordingly.
- ii) It shall be the sole responsibility of the prospective bidders to check the website <http://etender.up.nic.in> from time to time for any amendment in the e-bid document. In case of failure to get the amendments, if any, SVPUA&T shall not be responsible for it.
- iii) In order to allow prospective e-Bidders a reasonable time to take the amendment into account in preparing their e-Bids, SVPUA&T, at his discretion, may extend the deadline for the submission of e-Bids. Such extensions shall be uploaded on the e-Procurement website <http://etender.up.nic.in>.

### **4) Language of e-Bid**

The e-Bid prepared by the bidder, as well as all correspondence and documents relating to the e-Bid exchanged by the bidder and SVPUA&T shall be written either in English or Hindi language. The correspondence and documents in Hindi must be accompanied by embedded/separate Hindi font files. Only English numerals shall be used in the e-Bid.

### **5) Documents Constituting the e-Bid**

The eBid prepared by the bidder shall comprise the following components:

(a) **Prequalification :-**

- (i) **Fee Details** - It will consist of the cost of bid document/ e-Bid processing fee document and prescribed earnest money in prescribed form.
- (ii) **Eligibility Criteria** – It will consist of the details as per the Tender Document.

(b) **Financial e-Bid** - Financial e-Bid will comprise of:

- **Price Schedule/BOQ** - includes Price Schedule/BOQ in XLS/PDF format to be filled in after downloading from the e-Procurement website for this e-bid.

**6) e-Bid Form**

The bidder shall complete the e-Bid Form and the appropriate Price Schedule/BOQ furnished in the e-Bid document.

**7) e-Bid Currencies**

Prices shall be quoted / calculated in Indian Rupees only.

**8) Documents Establishing bidder's Qualification**

- i) The bidder shall furnish, as part of its Technical e-Bid, documents establishing the bidder's qualification to perform the Contract if its e-Bid is accepted. The documentary evidence should be submitted by the bidder electronically in the PDF format. One copy of the technical bid alongwith all documents proof, shall be submitted by the successful bidder in the office of the Finance Officer, the failure of that may cause the rejection of the e-Bid.
- ii) The documentary evidence of bidder's qualification to perform the Contract if its e-Bid is accepted shall be as per Qualification Requirements specified in e-bid document.

**9) e-Bid Security/Earnest Money Deposit (EMD)**

- i) The bidder shall deposit e-Bid security/ EMD as per the e-Tender notice through NEFT/ RTGS only. The transaction detail must be provided along with the e-Bid.
- ii) Any e-Bid not secured in accordance with above shall be treated as non-responsive and rejected by SVPUA&T.
- iii) Unsuccessful bidder's e-Bid security will be returned promptly as possible after the acceptance of e-Bid.
- iv) The successful bidder's e-Bid EMD will be converted into security upon the bidder signing the Contract.
- v) The e-Bid security may be forfeited:

(a) if a bidder (i) withdraws its e-Bid during the period of e-Bid validity specified by the bidder on the e-Bid Form; or (ii) does not accept the correction of errors or (iii) modifies its e-Bid price during the period of e-Bid validity specified by the bidder on the e-Bid form or

(b) in case of a successful bidder, if the bidder fails:

- (i) To sign the Contract with SVPUA&T.

**10) Period of Validity of e-Bid**

- i) e-Bid shall remain valid for 90 days after the date of e-Bid opening prescribed by SVPUA&T. An e-Bid valid for a shorter period shall be rejected by SVPUA&T as non-responsive.
- ii) In exceptional circumstances, SVPUA&T may solicit the bidder's consent to an extension of the period of e-Bid validity. The request and the response thereto shall be made in writing. A bidder may refuse the request without forfeiting its e-Bid security. A bidder granting the request will not be required nor permitted to modify its e-Bid.

11) **Format and Signing of e-Bid**

- i) The bidder shall prepare one electronic copy each of the Technical e-Bid and Financial e- Bid separately.
- ii) The e-Bid document shall be digitally signed, at the time of uploading, by the bidder or a person or persons duly authorized to bind the bidder to the Contract. The later authorization shall be indicated by a scanned copy of written power-of-attorney accompanying the e-Bid. All the pages/ documents of the e-Bid that are to be uploaded shall be digitally signed by the person authorized to sign the e-Bid.

**(B) SUBMISSION of e-Bid**

1) **Submission of e-Bid**

The Bid Submission module of e-Procurement website <http://etender.up.nic.in> enables the bidders to submit the e-Bid online in response to this e-bid published by SVPUA&T. Bid Submission can be done only from the Bid Submission start date and time till the Bid Submission end date and time given in the e-bid. Bidders should start the Bid Submission process well in advance so that they can submit their e-Bid in time. The bidders should submit their e-Bid considering the server time displayed in the e-Procurement website. This server time is the time by which the e-Bid submission activity will be allowed till the permissible time on the last/end date of submission indicated in the e-bid schedule. Once the e-Bid submission date and time is over, the bidders cannot submit their e-Bid. For delay in submission of e-Bid due to any reasons, the bidders shall only be held responsible.

The bidders have to follow the following instructions for submission of their e-Bid:

- i) For participating in e-Bid through the e-bidding system, it is necessary for the bidders, already registered with SVPUA&T, also to be the registered users of the e-Procurement website [http:// etender.up.nic.in](http://etender.up.nic.in). The bidders must obtain a User Login Id and Password by registering themselves if they have not done so previously for registration.
- ii) In addition to the normal registration, the bidder has to register with his/her **Digital Signature Certificate (DSC)** in the e-bidding system and subsequently he/she will be allowed to carry out his/her e-Bid submission activities. Registering the Digital Signature Certificate (DSC) is a onetime activity. Before proceeding to register his/her DSC, the bidder should first log on to the e-bidding system using the User Login option on the home page with the Login Id and Password with which he/ she has registered. For successful registration of DSC on e-Procurement website <http://etender.up.nic.in> the bidder must ensure that he/she should possess Class-2/ Class-3 DSC issued by any certifying authorities approved by Controller of Certifying Authorities, Government of India, as the e-Procurement website [http:// etender.up.nic.in](http://etender.up.nic.in) is presently accepting DSCs issued by these authorities only. The bidder can obtain User Login Id and perform DSC registration exercise above even before e-Bid submission date starts. SVPUA&T shall not be held responsible if the bidder tries to submit his/her e-Bid at the last moment before end date of submission but could not submit due to DSC registration problem.
- iii) The bidder can search for active bids through "Search Active bids" link, select a bid in which he/she is interested in and then move it to 'My Bids' folder using the options available in the e-Bid Submission menu. After selecting and viewing the bid, for which the bidder intends to e-Bid, from "My Bids" folder, the bidder can place his/her e-Bid by clicking "Pay Offline" option available at the end of the view bid details form. Before this, the bidder should download the e-bid document and Price Schedule/Bill of Quantity (BOQ) and study them carefully. The bidder should keep all the documents ready as per the requirements of e-bid

document in the PDF format except the Price Schedule/Bill of Quantity (BOQ) which should be in the XLS format (Excel sheet).

- iv) The bidder should read the Terms & Conditions carefully before proceeding to fill in the cost of bid document/ e-Bid processing fee and EMD payment details. After entering and saving the cost of bid document/ e-Bid processing fee and EMD details, the bidder should click "Encrypt & Upload" option given in the payment details form so that "Bid Document Preparation and Submission" window appears to upload the documents as per Technical (Fee details, Qualification details, e-Bid Form and Technical Specification details) and financial (e-Bid Form and Price Schedule/BOQ) schedules/packets given in the bid details. The details available in the scanned copy of bid form cost and of EMD shall be verified by SVPUA&T and in case of any discrepancy the e-bid shall be rejected.
- v) Next the bidder should upload the Technical e-Bid documents for Fee details (Cost of bid document/ e-Bid processing fee and EMD), Qualification details. Before uploading, the bidder has to select the relevant Digital Signature Certificate. He may be prompted to enter the Digital Signature Certificate password, if necessary. For uploading, the bidder should click "Browse" button against each document label in Technical and Financial schedules/packets and then upload the relevant PDF/XLS files already prepared and stored in the bidder's computer. The required documents for each document label of Technical (Fee details, Qualification details, e-Bid Form and Technical Specification details) and financial (e-Bid Form and Price Schedule/BOQ) schedules/packets can be clubbed together to make single different files for each label.
- vi) The bidder should click "Encrypt" next for successfully encrypting and uploading of required documents. During the above process, the e-Bid documents are digitally signed using the DSC of the bidder and then the documents are encrypted/locked electronically with the DSC's of the bid openers to ensure that the e-Bid documents are protected, stored and opened by concerned bid openers only.
- vii) After successful submission of e-Bid document, a page giving the summary of e-Bid submission will be displayed confirming end of e-Bid submission process. The bidder can take a printout of the bid summary using the "Print" option available in the window as an acknowledgement for future reference.
- viii) Department reserves the right to cancel any or all e-Bids without assigning any reason.

## 2) **Deadline for Submission of e-Bid**

- i) e-Bid (Technical and Financial) must be submitted by the bidders at e-Procurement website <http://etender.up.nic.in> not later than the prescribed date and time (as the server time displayed in the e-Procurement website).
- ii) SVPUA&T may, at its discretion, extend this deadline for submission of e-Bid by amending the e-Bid document, in which case all rights and obligations of SVPUA&T and bidders previously subject to the deadline will thereafter be subject to the deadline as extended.

## 3) **Late e-Bid**

The server time indicated in the Bid Management window on the e-Procurement website <http://etender.up.nic.in> will be the time by which the e-Bid submission activity will be allowed till the permissible date and time scheduled in the e-bid. Once the e-Bid submission date and time is over, the bidder cannot submit his/her e-Bid. Bidder has to start the Bid Submission well in advance so that the submission process passes off smoothly. The bidder will only be held responsible if his/her e-Bid is not submitted in time due to any of his/her problems/faults, for whatsoever reason, during e-Bid submission process.

## 4) **Withdrawal and Resubmission of e-Bid**

- i) At any point of time, a bidder can withdraw his/her e-Bid submitted online before the bid submission end date and time. For withdrawing, the bidder should first log in using his/ her Login Id and Password and subsequently by his/her Digital Signature Certificate on the e-Procurement website <http://etender.up.nic.in>. The bidder should then select "My Bids" option in the Bid Submission menu. The page listing all the bids submitted by the bidder will be displayed. Click "View" to see the details of the e-Bid to be withdrawn. After selecting the "Bid Withdrawal" option, the bidder has to click "Yes" to the message "Do you want to withdraw this bid?" displayed in the Bid Information window for the selected bid. The bidder also has to enter the bid Withdrawing reasons and upload the letter giving the reasons for withdrawing before clicking the "Submit" button. The bidder has to confirm again by pressing "Ok" button before finally withdrawing his/her selected e-Bid.
- ii) No e-Bid may be withdrawn in the interval between the deadline for submission of e-Bids and the expiration of period of e-Bid validity. Withdrawal of an e-Bid during this interval shall result in the bidder's forfeiture of his/her e-Bid security.
- iii) The bidder can re-submit his/her e-Bid as and when required till the e-Bid submission end date and time. The e-Bid submitted earlier will be replaced by the new one. The payment made by the bidder earlier will be used for revised e-Bid and the new e-Bid submission summary generated after the successful submission of the revised e-Bid will be considered for evaluation purposes. For resubmission, the bidder should first log in using his/her Login Id and Password and subsequently by his/her Digital Signature Certificate on the e-Procurement website <http://etender.up.nic.in>. The bidder should then select "My Bids" option in the Bid Submission menu. The page listing all the bids submitted by the bidder will be displayed. Click "View" to see the details of the e-Bid to be resubmitted. After selecting the "Bid Resubmission" option, click "Encrypt & Upload" to upload the revised e- Bid documents.
- iv) The bidders can submit their revised e-Bids as many times as possible by uploading their e-Bid documents within the scheduled date & time for submission of e-Bids.
- v) No e-Bid can be resubmitted subsequently after the deadline for submission of e-Bids.

## **(C) OPENING AND EVALUATION OF e-Bid**

### **1) Opening of e-Bid by SVPUA&T**

- i) SVPUA&T will open all e-Bids, in the presence of bidders' representatives who choose to attend at prescribed time on the prescribed date of opening at SVPUA&T office. The bidder's representatives who are present shall sign evidencing their attendance. In the event of the specified date of e-Bid opening being declared a holiday for SVPUA&T, the e-Bids shall be opened at the appointed time and place on the next working day.
- ii) The bidder's names and the presence or absence of repulsion e-Bid security and such other details as SVPUA&T at its discretion may consider appropriate, will be announced at the opening. The name of such bidders not meeting the requirement shall be notified.

### **2) Opening of Financial e-Bid**

- i) The financial e-Bids of qualified bidders shall be opened on the same day in the presence of bidders. The name of bidders, Price quoted for various items etc will be announced in the process.
- ii) SVPUA&T will prepare the minutes of the e-Bid opening.

### **3) Clarification of e-Bid**

- i) During evaluation of e-Bid, SVPUA&T may, at its discretion, ask the bidder for a clarification of his/her e-Bid. The request for clarification and the response shall be in writing.

4) **Evaluation of e-Bid and Evaluation Criteria**

SVPUA&T will examine the e-Bid to determine whether they are complete, whether they meet all the conditions of the Contract, whether required cost of bid document/ e-Bid processing fee, e-Bid security and other required documents have been furnished, whether the documents have been properly digitally signed, and whether the e-Bids are generally in order. Any e-Bid or e-Bids not fulfilling these requirements shall be rejected.

5) **Contacting SVPUA&T**

- i) No bidder shall contact SVPUA&T on any matter relating to his/her e-Bid, from the time of the e-Bid opening to the time the Contract is awarded. Any effort by a bidder to influence SVPUA&T in its decisions on e-Bid evaluation, e-Bid comparison or contract award may result in rejection of the bidder's e-Bid.
- ii) In the event of any information furnished by the agency is found false or fabricated the minimum punishment shall be debarred / blacklisting from SVPUA&T works and the legal proceeding can also be initiated.

**(D) AWARD OF CONTRACT**

1) **Award Criteria**

SVPUA&T will award the contract to the lowest evaluated successful Bidder whose bid has been determined to be responsive to all the conditions of the contract of the Bidding Document.

2) **Department's right to accept any e-Bid and to reject any or all e-Bids**

SVPUA&T reserves the right to accept or reject any e-Bid, and to annul the e-Bid process and reject all e-Bids at any time prior to contract award, without thereby incurring any liability to the affected bidder or bidders.

3) **Notification of Award**

- i) Prior to the expiration of the period of e-Bid validity, SVPUA&T will notify the successful bidder in writing by letter/e-mail/fax, that its e-Bid has been accepted.
- ii) The notification of award will constitute the formation of the Contract.

4) **Signing of Contract**

On completion of eTendering process a contract Agreement/Bond shall be drawn between the Finance Officer and the Contractor.





Tender for Establishment of IISR Model Jaggery Unit at  
KVK Hastinapur (Meerut) and KVK Muzaffarnagar-II

**TECHNICAL BID**

Tender No: 03/SVP/2021-22

01	फर्म का नाम		Page No*
02	फर्म का पंजीकरण संख्या		
03	पैन संख्या		
04	Goods & Service Tax (GST) पंजीकरण संख्या		
05	उपकरण निर्माता अथवा डीलर/सप्लायर्स/सेवाप्रदाता		
06	उपकरण निर्माता फर्म द्वारा स्थानीय सप्लायर्स/डीलर को जारी किये गये प्रमाण-पत्र (Valid Authorization letter) की स्वप्रमाणित/सत्यापित प्रतिलिपि। <b>List out name of each brand/ company.</b>	1. ... 2. ... 3. ... 4. ... 5. ....	
07	Make/brand of equipment quoted in the tender. <b>List out name of each brand/ company.</b>	1. ... 2. ... 3. ... 4. ...	
08	Proof of Annual turnover Balance Sheet certified by C.A. (Last Two Financial years) (Rs. 140.00 Lakh each Financial year)	FY 2018-19 (Financial Year)	
		FY 2019-20 (Financial Year)	
09	ITR .(Last Two Financial years / वित्तीय वर्ष 2018-19 एवं 2019-20)	AY-2019-20 (Assessment Year)	
		AY- 2020-21 (Assessment Year)	
10	सम्बन्धित कार्य में 02 वर्ष का अनुभव (Certificate/Documentary evidence of Government Organization/Public or Private Company/ recognized academic Institution and University)		
11	Duly attested self declaration/घोषणा पत्र on stamp paper of Rs. 10/-		
12	EMD(धरोहर धनराशि) UTR/Transaction No .....Amount..... Date.....Time.....Name of Bank.....		
13	e-Bid Processing fee UTR/Transaction No .....Amount -1500/- Date.....Time.....Name of Bank.....		
<p><b>*Note: Page numbering of document in tender file uploaded on the portal is necessary. The page number of supporting document must be mentioned in the format (Technical bid/ Equipment verification sheet).</b></p>			

1. तकनीकी बिड एवं निविदा के दस्तावेज को पूर्ण रूप से भरकर अपलोड किया जाना अनिवार्य है।
2. उपरोक्त के सम्बंध में **Fee-EMD** के लिये किये गये **RTGS/NEFT** का **UTR/Transaction No**, घोषणा पत्र, साक्ष्य, स्वप्रमाणित प्रमाण-पत्र आदि अनिवार्य रूप से आनलाईन पोर्टल पर अपलोड किये जायें।
3. निविदा का परीक्षण उपरोक्त बिन्दुओं पर केवल अपलोड किये गये अभिलेखों से ही किया जायेगा।
4. तकनीकी बिड के क्रम संख्या 01 से 13 में सफल फर्मों के उपकरणों का ही अवलोकन किया जायेगा।

5. आवेदन किये गये उपकरणों के लिये **Equipment Technical specification sheet (page 14 to 22)** के प्रत्येक कालम में वाछित जानकारी भरना अनिवार्य है।
6. Jaggery Unit की स्थापना से सम्बन्धित सभी कार्य IISR की Specification के अनुरूप एक ही संस्था द्वारा पूर्ण किया जाना आवश्यक है।
7. Jaggery Unit के शेड का निर्माण डिजाईन के अनुसार कुल क्षेत्रफल 192 वर्ग मीटर में होना है।

**Signature .....**  
**Name of Firm.....**  
**Address in Full.....**  
**Tel.No. (O) (Res).....**

### **Terms and conditions for the tender**

1. Tenderer's are requested to enclose a copy of their valid certificate of PAN number with their tender.
2. The prices /rates of the instruments quoted should be indicated in words as well as in figures in INR only.
3. Tenders received without depositing e-Bid processing fee/ EMD amount will not be considered at all.
4. The firms should give a declaration along with their technical bids that rates quoted in their financial bid are firm/valid for a minimum of one year period from the date of opening of tender
5. The firm should have valid GST Number details and last 02 years balance sheet and ITR document as required.
6. The supplier should be an Original Equipment Manufacturer (OEM) company or authorized dealers.
7. All Laboratory Equipments items supplied should be as per standard specifications given. If the items are not found satisfactory, the same will be sent back and all the expenditure will be borne by the supplier.
8. The supplier should have complain redressal capacity to address it within 48 hours of complaint.
9. In-case of exclusive distributor/manufacturer, authorization certificate is required for imported products.
10. The material should be delivered at "**Central Store, Sardar Vallabhbhai Patel University of Agriculture & Technology, Modipuram, Meerut -250110 (U.P.) INDIA**".
11. Free delivery and proper installation of the equipments at the site is mandatory.
12. Transit Insurance will be borne by supplier till the supply reaches the destination.
13. Any legal disputes that may arise out of the contract shall be subject to the jurisdiction of a court in Meerut (U.P.), India.
14. The rates of taxes, if any, should be clearly mentioned. Otherwise it will be presumed that the rates quoted are inclusive of all taxes.
15. The number of quantity may vary according to the requirements of the Institution. The University has the right to change the quantity of orders or refuse the supply in parts or full or cancel the order without assigning any reason. No claim has to be made against the cancellation of change in the quantity of the order.
16. The supplier shall supply all the items within 30 days from the date of receipt of the Purchase Order to the door delivery at central store, SVPUA&T, Meerut.
17. **Undertakings:** The supplier has to give undertaking that the materials supplied are the original materials produced by the manufacturer.
18. **Right Reserved by the University:** The University reserves the right to accept or reject any tender or part thereof without assigning any reason and shall also be subject to the availability of sanctioned budget.
19. **The supplier should provide supply to** two nationalized private/government organizations.
20. **Warranty:** The supplier/bidder shall provide guarantee that all the equipments supplied as given in **equipment technical specification sheet**, to be purchased under this tender. They shall be of the best quality and workmanship and new in all respect.
21. The supplier/bidder shall guarantee in the form of **declaration** that the said equipment would continue to conform to the description and quality aforesaid for at least a period of 12 months (or more as given in tender document) from the date of installation of the equipment/item. If during that period, the equipment/ item be discovered not to conform to the description and working upto the mark of the purchaser, the supplier must have to rectify the equipment/item or replace the part of item/equipment.
22. At least two year maintenance has to be done by the firm and parts will be supplied by the concerned.
23. After erecting and commission of the unit IISR Model Jaggery Unit will be inspect by the IISR experts to their satisfaction.
24. A single firm will be responsible to accomplish all the related works including instruments/equipments for the establishment of Jaggery Unit at both centers as per specification of IISR Lucknow.

**फर्म द्वारा रूपये 10/- के स्टाप पेपर पर नोटरी सहित दिया जाना वाला  
घोषणापत्र का प्रारूप**

(नोट :- घोषणा पत्र स्टाम्प पेपर पर ही उपलब्ध कराना अनिवार्य है। स्टाम्प पेपर के साथ सादे कागज पर नोटरी कराकर संलग्न करना सही नहीं माना जायेगा।)

**(घोषणा –पत्र)**

मैंने (श्री..... पता.....  
.....) निविदा-प्रपत्र में दरों को अपलोड करने से पूर्व सभी कार्यों के सम्बन्ध में सभी दिशा निर्देश एवं शर्तों की भली –भांति अध्ययन अपने पूर्ण ज्ञान एवं विश्वास से किया है तथा मैं यह भी घोषणा करता हूँ कि मेरा सरदार वल्लभभाई पटेल कृषि एवं प्रौद्योगिक विश्वविद्यालय , मेरठ के साथ किसी भी प्रकार का विवाद नहीं है और न ही किसी न्यायालय में विश्वविद्यालय से सम्बन्धित कोई विवाद लम्बित है।

अपलोड किये गये सभी प्रमाण-पत्रों की सत्यापित छाया प्रतियां संलग्न कर दी है यदि मेरे द्वारा कोई तथ्य छिपाया गया हो अथवा झूठा/गलत तथ्य प्रेषित किया गया हो अथवा आवंटन उपरान्त कोई तथ्य गलत पाया जाता है तो कृषि विश्वविद्यालय किसी भी प्रकार का निर्णय लेने के लिये स्वतंत्र है। जिसे मैं पूर्ण रूप से मानने के लिये अपनी स्वीकृति प्रदान करता हूँ।

**(हस्ताक्षर)**

निविदादाता/विक्रेता का नाम एवं पूर्ण पता

**2. Requirements of IISR model jaggery unit for Krishi Vigyan Kendra Chitaura (Muzaffarnagar) and Hastinapur (Meerut) one set for each KVK**

<b>Particular</b>	<b>Qty.</b>
<b>Crushing unit</b> Cane Crusher, capacity 10q/h, gear type. Power operated with electric panel/diesel engine operated with diesel engine and related foundation	02 <b>(One set for each KVK)</b>
<b>Filtration unit</b> Vibro filter system(SS) and fine wire mesh pre filters(capacity 700-1000litres/hr)	02 <b>(One set for each KVK)</b>
<b>Clarification and boiling unit</b> Scum removal tank(SS) with tap(50 litres), juice settling tank(200litres),Three 1550-1650mm diameter MS Pans with base thickness of 25mm and 18mm and 10mm respectively, two gate valve, furnace with chimney	02 <b>(One set for each KVK)</b>
<b>Cooling, moulding and packaging unit</b> SS Cooling pan(5 feet by 3 feet by 0.75 feet with wheels and jack arrangement), four SS moulding frame set with platform, sealing machine, jaggery tools like laddle, khurpa, scoop etc. , moulding platform with stone top	02 <b>(One set for each KVK)</b>
<b>Laboratory Equipments</b> Portable pH meter(0-14), brix meter(0-50), IR temperature recorder(upto 500°C) and Moisture meter( upto 25%)	02 <b>(One set for each KVK)</b>
<b>Accessories</b> Transfer plate, juice transfer pump, jaggery transfer pump, Pipes , fittings etc.	02 <b>(One set for each KVK)</b>
<b>Jaggery shed</b> at least 100 sq.m with pillar and cantilever arrangement with asbestos sheet/ locally available material for roofing, tile flooring, false ceiling(moulding area), arrangement for fume removal	02 <b>(One set for each KVK)</b>

**Equipment Technical specification sheet (आवेदन किये गये उपकरणों के लिये प्रत्येक कालम में वाछित जानकारी भरना अनिवार्य है)**

S. No	Equipment Name	Required Specification	To be fill by the bidder (The page number of supporting document must be mentioned in the format (Technical bid/ Equipment verification sheet))					
			Brand / Make and Model No.	उपकरणों का विस्तृत स्पेशिफिकेशन Supported with original printed Brochure/ Catalogue	Brand authorizatio n/ Manufaturer	List of equipment clients in National/ Govt. /Research Institutes	US- FDA/CE/IVD certification (as specified for the specific equipment)	Warranty in years ( <b>minimum 01 Year</b> ) or as specified for the specific equipment.
			01	02	03	04	05	06
1.	<b>Crushing unit</b>	<p>Mills-1, C.I. Graded Rollers – 3.</p> <p>A - Roller Dia - 213mm – Length - 216 mm, A-Roller mm.</p> <p>B - Roller Dia - 213 mm – Length - 216 mm, B- Roller mm.</p> <p>C - Roller Dia - 196 mm – Length - 216 mm, C- Roller mm.</p> <p>Mill base fabricated from M.S. Channels.</p> <p>Side Plate fabricated from tested mild steel plates.</p> <p>90 mm Thick Graded M.S. Shafts.</p> <p>Gun Metal top Roller Bush half square/half round.</p> <p>Gun Metal B&amp;C Roller Bush full round with M.S. forged Bush Holder.</p> <p>Top Caps fabricated from M.S. Plates.</p> <p>Side Caps fabricated from M.S. Plates.</p> <p>Long Studs to hold the Side Caps from the both sides.</p> <p>Setting Keys for B&amp;C Roller Holder to avoid movement.</p> <p>Heavy &amp; Big Grease Cup &amp; Pipes.</p> <p>A &amp; B Roller Scrapers fabricated from M.S. plates.</p>	Brand/ Make: ..... Model No.: .....	Brochure enclosed: <b>Yes/ No</b>  Page No.:	Manufatur er: <b>Yes/ No</b> Page No.:  Authorize d dealer: <b>Yes/ No</b> Valid authorizati on letter.: Yes/ No Page No.:	Page No.: ... As per enclosed format	Page No. ..... of supporting document:	Warranty : ... year  Page No.:

		<p>C-roll Scraper Stand &amp; C-roll Scrape fabricated M.S. plates.</p> <p>Crusher Side Gear shall be having hub cut 11 teeth.</p> <p>Crusher side cover shall be fabricated from Mild Steel Sheet.</p> <p>Sugarcane Bagasse Exit Window shall be fabricated Steel plates.</p> <p>Juice Collecting bottom Tray shall be Mild Steel Co Mild Steel Sheet.</p> <p>Crushing Capacity -850-1050 Kgs Per Hour</p> <p>Single Coupling, Coupling Rpm -7 / 8.</p> <p>Planetary Gear box 7.5 H.P. – 1 Nos</p> <p>15 H.P. Diesel Engine – 1 Nos</p> <p>Diesel Engine Attachment – 1Set</p> <p>M.S. Safety Cover for Gear box &amp; Motor. – 1Nos</p> <p>1<sup>ST</sup> time filling Lubricants like Oil &amp; Grease. – 1 Set</p> <p><b>M.S. Foundation Frame. – 1 Nos</b></p> <p><b>Crusher Foundation Bolts – 10 Nos</b></p>						
2.	<b>Filtration unit</b>	<p><b>VIBRO FILTER-</b></p> <p>24" Vibro Sifter Contact Part :- SS 304</p> <p>Non Contact Part :- MS Painted</p> <p>Double deck machine</p> <p>Mesh Size :- 80 # &amp; 100 #</p> <p>Electric motor 1.5 H.P.</p> <p><b>FILTER TANK WITH 2" S.S. NIPPLE</b></p> <p>10 Mesh S.S. Screen – 1 Nos</p>	<p>Brand/ Make: .....</p> <p>Model No.: .....</p>	<p>Brochure enclosed: <b>Yes/ No</b></p> <p>Page No.:</p>	<p>Manufacturer: <b>Yes/ No</b></p> <p>Page No.:</p> <p>Authorized dealer: <b>Yes/ No</b></p> <p>Valid authorization letter.: Yes/ No</p> <p>Page No.:</p>	<p>Page No.: ... As per enclosed format</p>	<p>Page No. .... of supporting document:</p>	<p>Warranty : ... year</p> <p>Page No.:</p>
3.	<b>Clarification and boiling unit</b>	<p><b>SCUM REMOVER TANK WITH TAP-50 LTRS</b></p> <p>Construction – Fabricated with Stainless Steel Sheets.</p> <p>Capacity – 50 Ltrs.</p> <p>Type – Round Type.</p> <p>With Tap.</p>	<p>Brand/ Make: .....</p> <p>Model No.: .....</p>	<p>Brochure enclosed: <b>Yes/ No</b></p> <p>Page No.:</p>	<p>Manufacturer: <b>Yes/ No</b></p> <p>Page No.:</p>	<p>Page No.: ... As per enclosed format</p>	<p>Page No. .... of supporting document:</p>	<p>Warranty : ... year</p> <p>Page No.:</p>

		<p><b>JUICE SETTLING TANK 200 LTR</b>  Construction – Fabricated with Stainless Steel Sheets.  Capacity – 200 Ltrs.  Type – Square Type.</p> <p><b>OPEN PAN SET</b></p> <ul style="list-style-type: none"> <li>● Main Open Pan Round – 1 Nos.  Pan Length – 1525 mm.  Thickness of Pan – 25 mm.  Pan Deepness – 80 mm.  Border (Collar) Thickness – 6 mm.  Border (Collar) Height – 220 mm.  Pan Handles Thickness 25 mm – 4 Nos.</li> <li>● 2<sup>nd</sup> Open Pan Round – 1 Nos.  Pan Length – 1525 mm.  Thickness of Pan – 20 mm.  Pan Deepness – 80 mm.  Border (Collar) Thickness – 6 mm.  Border (Collar) Height – 220 mm.  Pan Handles Thickness 25 mm – 4 Nos.  Juice Exit Bottom Pipe – 50 mm.  Gate Valve (Brass) 50 mm- 1 Nos.</li> <li>● Gutter Pan – 1 Nos.  Base Thickness – 12 mm  Base size – L-1524 mm x W-914 mm.  Side Plates Thickness–6 mm.  Side Plates Size–L-1524 mm x H-204 mm–2 NOS, L-914 mm x H-204 mm –2 Nos.  Angle Iron – 35 x 5 mm.  Outlet Pipe - Length – 6”, Dia – 50 mm (4”).  Brass Gate Valve – 50 mm.</li> </ul> <p><b>FURNACE WITH CHIMNEY (As per Drawing)</b>  Complete Raw Materialfor Construct Furnaceand Chimney.</p>			<p>Authorize d dealer:  <b>Yes/ No</b>  Valid authorizati on letter.:  <b>Yes/ No</b>  Page No.:</p>			
4.	<b>Cooling, moulding and</b>	<p><b>STAINLESS STEEL COOLING PAN</b>  Pan Material - M.S. Framing fabricated</p>	Brand/ Make: .....	Brochure	Manufatur	Page No.:	Page No.	Warranty



	<p><b>packaging unit</b></p>	<p>with S.S. 304 sheets.  Pan size - 60" x 36" x 9".  Trolley Material – S.S. 304 Pipes.  Trolley size - 61" x 51" x 10.5".  6 Wheels with locking system.  Jack system for up &amp; down movement</p> <p><b>S.S. JAGGERY MOULDING FRAME WITH PLATFORM– 1" x 1" x 1"</b></p> <p>Material – Stainless Steel 304.  Size – 23.5" x 22".  Scraper Small – 1 Nos  Scraper Big – 1 Nos  Hammer for Jaggery removal from Frame – 1 NOS  S.S. Rod with O-Ring  Mould size – 1" x 1" x 1" – 20 Grams each.  Total Moulds in 1 Frame - 342 Nos.</p> <p>➤ Platform Material – S.S. 304.  Platform size - 25" x 24".</p> <p><b>JAGGERY POUCH SEALING MACHINE</b></p> <p><b>JAGGERY TOOLS</b></p> <p>C.I.(Fire Bar) – 1 Set.  M.S. Tank for Bhindi Juice 1.5' x 1.5'– 1 Nos.  M.S. Tank for Juice Mud 1.5' x 1.5' with Nipple &amp; Gate Valve – 1 Nos.  Scoop Small with S.S. Handle (for juice transferring one pan to another) – 2 Nos.  Scoop Big with S.S. Handle (for juice transferring one pan to another) – 2 Nos.  Scum Remover with S.S. Handle – 2 Nos.  Stainless Steel Mug Big – 1 Nos.  Stainless Steel Mug Small – 1 Nos.</p>	<p>Model No.:  .....</p>	<p>enclosed:  <b>Yes/ No</b></p> <p>Page No.:</p>	<p>er: <b>Yes/ No</b></p> <p>Page No.:</p> <p>Authorize d dealer:  <b>Yes/ No</b></p> <p>Valid authorizati on letter.:  Yes/ No</p> <p>Page No.:</p>	<p>...  As per enclosed format</p>	<p>..... of supporting document:</p>	<p>: ... year</p> <p>Page No.:</p>
--	------------------------------	--	------------------------------	---	--	--	--------------------------------------	------------------------------------

		<p>Wooden Laddle with S.S. Handle – 2 Nos.</p> <p>S.S. Khurpa with S.S. Handle – 4 Nos.</p> <p>S.S. Supdi with S.S. Handle – 1 Nos.</p> <p><b>JAGGERY MOULD TABLE</b>  Size – 25" x 60"  Structure – M.S. WITH GRANITE TOP  WHEELS WITH LOCKING SYSTEM – 4 Nos.</p>						
5.	<b>LABORATORY EQUIPMENTS</b>	<p><b>Portable pH meter</b></p> <ul style="list-style-type: none"> <li>● Economical cost digital PH meter</li> <li>● General purpose applications.</li> <li>● Easy operation.</li> <li>● Compact size, light weight.</li> <li>● Display LCD, size : 45 mm x 29 mm.</li> <li>● Measurement pH.</li> <li>● Range/Resolution 0 to 14 pH x 0.01 pH.</li> <li>● Accuracy ± 0.07 pH (pH 5 - pH 9), ± 0.1 pH (pH 4 - pH 10)</li> <li>● ± 0.2 pH (pH 1 - pH 3.9, pH 10.1 - pH 13).</li> <li>● Main instrument only</li> <li>● Input Impedance 10<sup>12</sup> ohms.</li> <li>● PH range Temp. Not necessary to adjust.</li> <li>● Compensation</li> <li>● Sampling Time Approx. 0.4 second.</li> <li>● Operating Temperature 0 to 50 (32 to 122).</li> <li>● Operating Humidity Less than 80% RH.</li> <li>● Calibration VR External pH 4 (slope adj.) &amp; pH 7 (Cal. adj.) calibration adjustment VR.</li> <li>● Power Supply 006P DC 9V battery.</li> <li>● Power Consumption Approx. 2.0 mA.</li> <li>● Dimension 131 x 70 x 25 mm, (5.3 x 2.4 x 1.3 inch).</li> <li>● Weight 153 g/0.34 LB (including battery).</li> <li>● PH electrode Any connector PH Electrode with (Optional) BNC connector.</li> <li>● Standard Instruction Manual..... 1 PC.</li> <li>● Accessories</li> <li>● Optional pH electrode, pH 4, pH 7 buffer solution,</li> </ul> <p>Accessories Carrying case, Case holder.</p>	<p>Brand/ Make: .....</p> <p>Model No.: .....</p>	<p>Brochure enclosed: <b>Yes/ No</b></p> <p>Page No.:</p>	<p>Manufacturer: <b>Yes/ No</b></p> <p>Page No.:</p> <p>Authorized dealer: <b>Yes/ No</b></p> <p>Valid authorization letter.: <b>Yes/ No</b></p> <p>Page No.:</p>	<p>Page No.: ...</p> <p>As per enclosed format</p>	<p>Page No. .... of supporting document:</p>	<p>Warranty : ... year</p> <p>Page No.:</p>
		<b>Portable Brix Meter (1-25' Brix)</b>						

		<ul style="list-style-type: none"> <li>• Cat. No. – 3810</li> <li>• Scale – Brix Temperature</li> <li>• Measurement Range - Brix : 0.0 to 53.0 % - Temperature : 10.0 to 100°C</li>   <li>• Resolution - Brix : 0.1% - Temperature : 0.1 °C</li> <li>• Measurement Accuracy - Brix : ±0.2 % - Temperature : ±1 °C</li> <li>• Temperature compensation range - 10 to 100 °C (Automatic Temperature Compensation)</li> <li>• Ambient Temperature - 10 to 40 °C</li> <li>• Output - NFC Forum Type 4 Tag - ISO/IEC 14443 Type A</li> <li>• Maximum number of data history - 100</li> <li>• Output item - Date Time, Brix [%], Temp [deg. C]</li> <li>• Sample Volume - 0.3mL</li> <li>• Measurement Time - 3 seconds</li> <li>• Power Supply - 2 x AAA alkaline batteries</li> <li>• Battery Life - Approx. 11,000 times measurement - (when alkaline batteries are used)</li> <li>• International Protection Class - IP65 Dust-tight and Protected against water jets.</li> </ul> <p>Dimensions &amp; Weight - 55(W)×31(D)×109(H)mm, 100g (Main Unit only)</p>					
		<p><b>Infra-Red</b> temperature recorder</p> <ul style="list-style-type: none"> <li>• temperature Range - 18 to 400°C (0 to 750°F)</li> <li>• Accuracy - -1°C (30°F) to 275°C (525°F) ±2% or ±2°C (±3.5°F) whichever is greater</li> <li>• -18°C (0°F) to -1°C (30°F) ±3°C (±5°F)</li> <li>• Repeatability - ±2% of reading, or ±2°C (±3°F), whichever is greater</li> <li>• Response time - 500 mSec, 95% response</li> <li>• Spectral response - 7–18 μm</li> <li>• Emissivity* - pre-set 0.95</li> <li>• Ambient operating range - 0 to 50°C (32 to 120°F)</li> <li>• Relative humidity - 10–95% RH noncondensing, @ up to 30°C (86°F)</li> <li>• Storage temperature - -20° to 65°C (-4° to 150°F) without battery</li> <li>• Weight / Dimensions - 227 g (0.5 lb); 152 x 101 x 38 mm (6 x 4 x 1.5 in)</li> <li>• Power - 9V Alkaline or NiCd battery</li> </ul>					

		<ul style="list-style-type: none"> <li>(included)</li> <li>Battery life (Alkaline) - 12 hrs</li> <li>Laser Class II - ✓</li> <li>Distance to Spot Size - 8:1</li> </ul> <ul style="list-style-type: none"> <li>Typical Distance to Target (Spot) - Up to 1.5m or 4 ft</li> <li>Display Hold (7 seconds) - ✓</li> <li>LCD Backlit - ✓</li> <li>Temperature Display - °C or °F selectable</li> <li>Display Resolution - 0.2°C (0.5°F)</li> <li>Options/Accessories - Nylon Holster</li> </ul> <p>Warranty - 1 Year**</p>						
		<p><b>Portable Moisture Meter (1-25%) - 1 Nos</b></p> <ul style="list-style-type: none"> <li>Size - 178 x 68 x 39mm</li> <li>Weight - 190g</li> <li>Range - 10mm LCD</li> <li>Display: 4 digits, 10mm LCD.</li> <li>Range: Moisture Content: 8~20%,</li> <li>Temp.: -10~65oC.</li> <li>Accuracy: Moisture: +1%,</li> <li>Temp.: +0.8.</li> <li>Resolution: 0.1.</li> <li>Operating Temperature: 0~50oC or 32~122oF.</li> <li>Operating Humidity: &lt; 0.8.Battery: 4x1.5AA (um-3).</li> <li>Size: 178 x 68 x 39mm.</li> </ul> <p>Weight: 190g (not including measuring probe and batteries)</p>						
6.	<b>ACCESSORIES</b>	<ul style="list-style-type: none"> <li>Jaggery Transfer Plate – 1 Nos.</li> <li>Juice Transferring Pump 2 H.P. With Wire &amp; Switch – 1 Nos.</li> <li>G.I. Pipe (2 Pipes x 20 Feet) &amp; Fittings. PVC Pipe 2” (6 Pipes X 3 Mtr&amp; Fittings – 1 Set.</li> </ul>	Brand/ Make: ..... Model No.: .....	Brochure enclosed: <b>Yes/ No</b>  Page No.:	Manufacturer: <b>Yes/ No</b> Page No.:  Authorized dealer: <b>Yes/ No</b> Valid authorization letter.: Yes/ No Page No.:	Page No.: ... As per enclosed format	Page No. .... of supporting document:	Warranty : ... year  Page No.:

7.	JAGGERY SHED	<p><b>Sub Structure</b></p> <ul style="list-style-type: none"> <li>➤ 10 column RCC structure up to the ground level.</li> <li>➤ Foundation of all columns has a size of 3 feet width x 3 feet length and depth as per S.B.C.</li> <li>➤ 4" PCC work will be done for all columns.</li> <li>➤ Foundation detail for all columns will be done as per structural drawings.</li> <li>➤ 10 columns will be casted up to the ground level and tide with RCC plinth beam having a size 300mm x 300mm at the outer periphery of the shed.</li> <li>➤ 300mm x 300mm M.S. plate having a thickness of 10mm with 16mm thick foundation bolts casted above column.</li> </ul> <p><b>Super Structure</b></p> <ul style="list-style-type: none"> <li>○ M.S. Pipe Columns 3657mm Height x 132mm Width x 5mm Thick (10 Nos)</li> <li>○ Ridge Beam 12300mm Length x 38mm Width x 2mm Thick (4 Nos)</li> <li>○ M.S. Purling 5150mm Length x 38mm Width x 76mm Height x 2 mm Thick (10 Nos)</li> <li>○ M.S. Purling 5000mm Length x 38mm Width x 76mm Height x 2 mm Thick (10 Nos)</li> <li>○ M.S. Purling 6150mm Length x 38mm Width x 76mm Height x 2 mm Thick (10 Nos)</li> <li>○ Corrugated Iron Sheet Roofing 0.5mm Thick</li> </ul> <p><b>Tile Flooring</b> Vitrified Tile flooring having a size of 600mm x 600mm will be fabricated in Moulding area of 5650mm x 11650mm area.</p> <p><b>False sealing</b> False Ceiling (Cement Sheets) under the roof will be fabricated in Moulding area of 5650mm x 11650mm area</p> <p><b>Compound Wall</b> 4 feet compound wall will be constructed in crushing area and moulding area</p>						
----	--------------	---	--	--	--	--	--	--

		<p><b>Glass &amp; Aluminum Section</b> Glass &amp; Aluminum Section with windows will be fabricated on Outer Periphery walls of Moulding area.</p> <p><b>Electric Fittings</b> Electric Fittings like Lights(15W 8nos.), Cables, Wiring, Switches And Fans(2 nos.) Etc. will be done in Moulding area.</p> <p><b>Main Gate</b> Main gate will be fitted in Moulding area on one side.</p> <p><b>FUME REMOVAL FANS</b> Fume Removal Fans will be fabricated on side wall in boiling area and will be over Two Circular Open Pans. Along with Electric starter panel</p>						
--	--	--	--	--	--	--	--	--

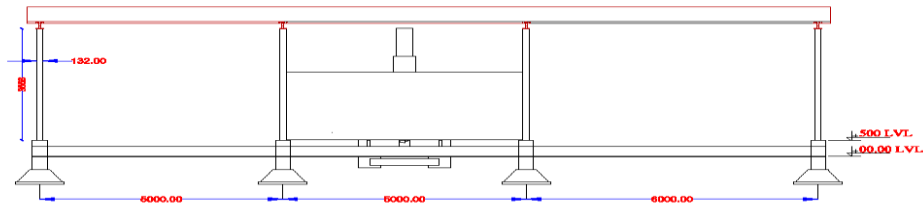

**ELEVATION**

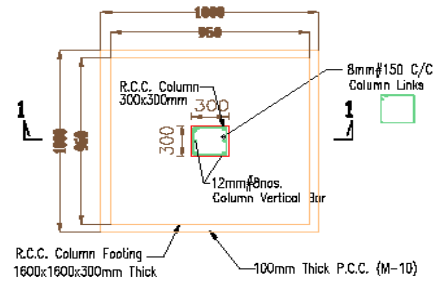
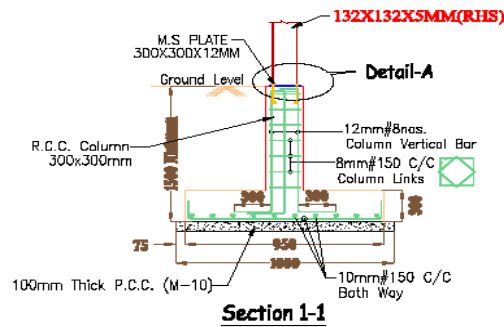
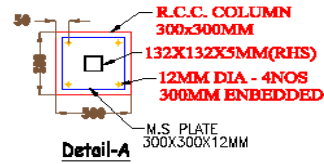

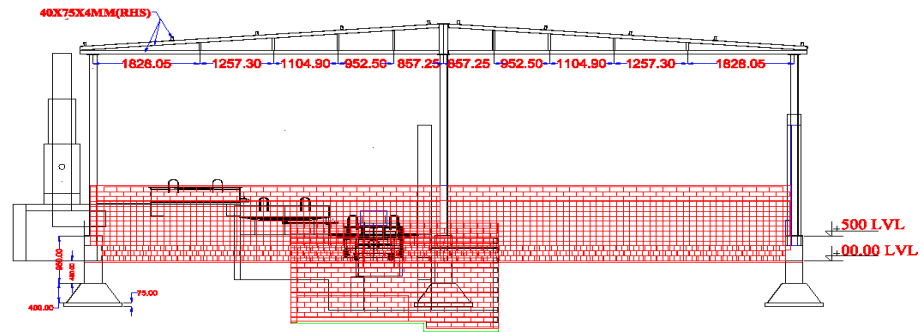

**SECTION - CC**

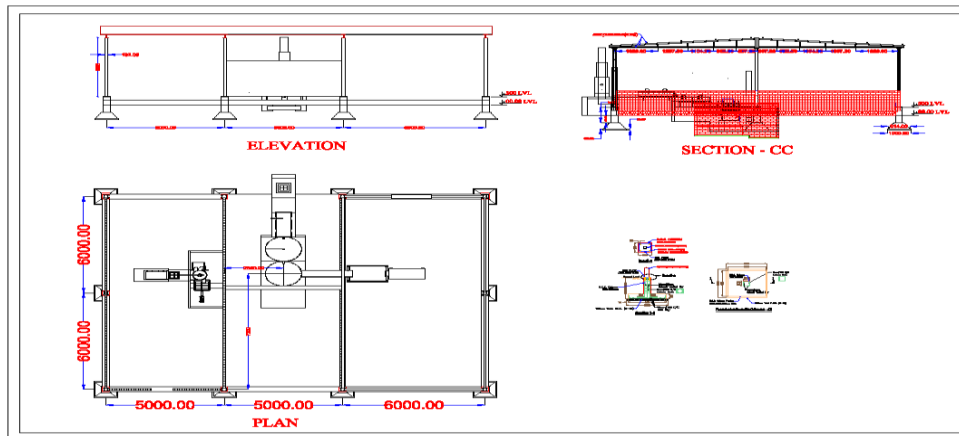



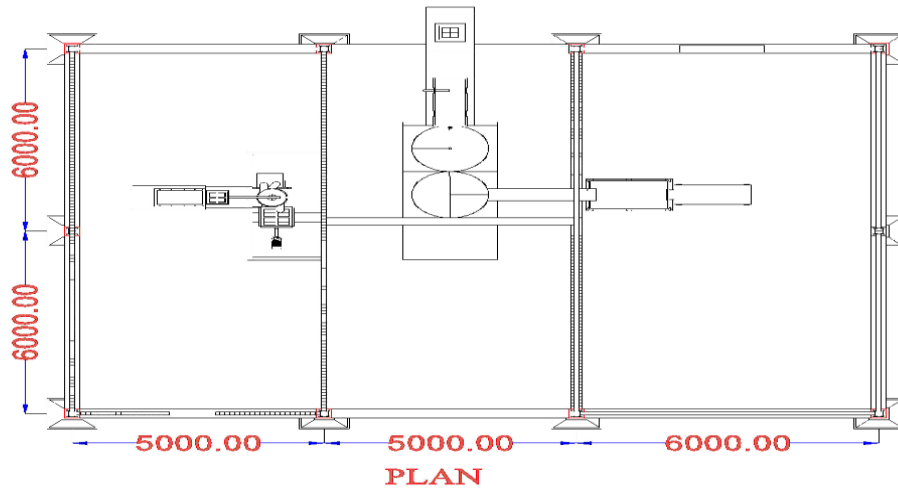

## GENERAL INSTRUCTIONS

1. The purchases/contract concluded as a result of this Tender Inquiry shall be governed by the "Terms & Conditions" and other relevant instructions as contained in this Tender Document.
2. The prices/rates quoted should be indicated in words as well as in figures and in INR only.
3. Tenderers are requested to quote their prices on a firm & fixed basis only for the entire period of the Contract. Tenders of the firms received with prices quoted on variable basis shall be rejected straightaway.
4. Quotations qualified by such vague and indefinite expressions such as "*subject to prior Confirmation*", "*subject to immediate acceptance*" etc. will be treated as vague offers and rejected accordingly.
5. Tenderers have to enclose a copy of their valid certificate of PAN No & GST No with their tender.
6. Tenders received without depositing e-Bid processing fee/ EMD amount will not be considered at all.
7. Ensure that all documents duly completed and signed are returned with their offer, failing which, the tender is liable to be treated as incomplete and ignored.
8. Tenderers may note that if the date of tender opening given in this Tender Document is declared a closed holiday by the State Government, the tender shall be opened on the next working day at the same timing. In such an event the closing hours for receipt of tenders in SVPUA&T, Meerut will stand automatically extended up to 15:00 hours of the next working day.
9. Late/delayed tenders received in University due to any reason whatsoever will not be accepted under any circumstances.
10. Tendering firms are at liberty to be present or authorize a representative to be present at the opening of the tender at the time and date as specified in the schedule. The name and address of the authorized representative to attend the opening of the tender on behalf of a tendering firm should be indicated in the tender. The representative so deputed should also bring with him a letter of authority from the firm for having been authorized to be present at the time of opening of tender. The name and address of permanent representative of the firm, if any, should also be indicated in the tender. Representatives of firms who have not submitted the tender or representatives not possessing authority letter from the tenderer or outsiders shall not be allowed to attend the tender opening.
11. Rates should be quoted on a firm & fixed price basis. Request for enhancement of contracted rates shall not be considered under any circumstances. Rates should be quoted for the goods of specific brand where the brand name is specified and the rates should not be above MRP. It may be noted that no compromise on quality would be made and no firm will be permitted to change the specifications mentioned in the tender notice and if any firm submits the quotations with changed specification, their quotations will be rejected.
12. The Firms should give a declaration along with their Technical Bids that rates quoted in their

Financial Bids are firm / valid for a minimum of one year from the date of opening of the Tender.

13. This tender is non-transferable.
14. Terms & Conditions as set out in this Tender Document shall have to be complied with by the tendering firm. Offers not complying with such terms & conditions shall be ignored / rejected at the discretion of this University.
15. Only Tenders received in the format prescribed in this tender document shall be considered. Tenders not received in the prescribed format shall be ignored and no correspondence in this regard will be entertained. Telegraphic/Telex/Fax/E-mail/Letter head / Quotations will not be accepted and ignored straightaway.
16. Tenders received after closing date and time prescribed in this tenders enquiry shall **NOT** be accepted under any circumstances.
17. This University reserves the right to reject any tender/all tenders in full or part thereof without assigning any reasons.
18. Not with standing the above, the University reserves the right to Seek previous work orders, references etc. and to accept or reject any quotations and to cancel the process and reject all tenders at any time prior to award of contract.
19. **The tenderer(s) whose rate is accepted will be notified for the award of contract by the University prior to expiration of the tender validity period. The terms and conditions stipulated in the tender document shall be fully applicable to the resultant contract and taken as an integral part of the contract concluded on the basis of this Tender Enquiry.**
20. While submitting the tender for this work, the tenderers will be **deemed to have read, understood and accepted** all the items and conditions stated in the tender document. Any doubts or clarifications with regard to the interpretation of the Terms & Conditions stipulated in this Tender Enquiry, may be got clarified from SVPUA&T, Meerut at least 03 days before tender closing date. Requests for postponing the tender opening date for the same shall not be accepted.
21. The tender shall be valid for the period of one year from the date of awarding the tender. Actual Supply Order may be placed from time to time against the awarded tender. No guarantee can be given as to the minimum or actual quantity of supply.
22. EMD will be returned to the unsuccessful at the earliest after the opening of tender.
23. University reserves the right to conclude parallel tender with a number of suppliers and place Orders on any of such firm that may be the most economical to it or suitable to its requirements.
24. If the successful Bidder fails to fulfill his obligations under this Tender i.e., Non-adherence to terms and conditions contained in this Tender, the University after due notice to the Supplier may blacklist the firm. In such events, the tender will stand terminated and the EMD/Performance Securities of such Firm shall be forfeited.
25. In the event of any disputes arising out of the execution of tender/Supply Orders, the matter will be referred to Vice Chancellor.
26. For judicial adjudication, the disputes, if any, arising out of the tender /Service Orders will be subject to the jurisdiction of the Courts in Meerut only.

- 27. Authorized Signatory/ Signing of Tender:** Individual signing the tender or other documents connected with contract must specify the capacity in which the tender documents are signed as:
- a) a sole proprietor of the concern or constituted attorney of such sole proprietor;
  - b) a partner of the firm, if it be a partnership firm, in which case he must have authority to execute contracts on behalf of the firm and to refer to arbitration disputes concerning the business of the partnership either by virtue of the partnership agreement or by a power of attorney duly executed by the partners of the firm.
  - c) Director or a principal officer duly authorized by the board of Directors of the Company, if it is a company.

**NOTES:**

- a) In case of partnership firms, a copy of the partnership agreement, or general power of attorney duly attested by a Notary Public, should be furnished on stamped paper duly sworn or affirmed by all the partners admitting execution of the partnership agreement or the general power of attorney. The attested copy of the certificate of registration of firm should also be enclosed along with the tender.
  - b) In case of partnership firms, where no authority to refer disputes concerning the business of partnership firm has been conferred on any partner, the tender and all other related documents must be signed by all partners of the firm.
  - c) A person signing the tender form or any documents forming part of the tender on behalf of another person should have an authority to bind such other person and if, on enquiry it appears that the persons so signing had no authority to do so, S.V.P.U.A.T. Meerut may, without prejudice, cancel the contract and hold the signatory liable for all costs, consequences and damages under the civil and criminal remedies available.
- 28. The tenderer should sign at each page of the tender and all its Annexure. NO PAGE SHOULD BE REMOVED /DETACHED FROM THE TENDER DOCUMENT.**
- 29. Terms of Delivery:** free of cost door delivery at Central Store, S.V.P.U.A.&T., Modipuram, Meerut.
- 30. Delivery period:** Within 30 days of the placement of confirmed supply order on the firm or as stipulated in the supply order.
- 31. Payment terms:** 100% payment shall be released on satisfactory receipt and installation of the goods/articles ordered. Advance payment will not be made under any circumstances.
- 32. Dispatch instructions:** Goods/articles are required to be delivered free of cost at the Central Store of SVPUA&T, Meerut on free delivery to the consignee premises. Purchaser will not pay separately for transit insurance and the supplier will be responsible till the entire goods/articles contracted for, arrive in good condition at the Central Store of SVPUA&T, Meerut.
- 33. GUARANTEE/ WARRANTY:**

The supplier shall guarantee that the stores, articles sold/supplied to the purchaser under this contract shall be of the best quality and workmanship and new in all respects and shall be strictly in accordance with the specification and particulars contained/ mentioned in the Tender enquiry. The supplier shall guarantee that the said goods/stores articles would continue to conform to the description and quality aforesaid for a period of twelve

months, from the date of installation of the said goods/stores/articles to the purchaser and notwithstanding the fact that the Purchaser may have inspected and /or approved the said goods /stores/articles, if during the aforesaid period of 12 months the said stores/goods/articles be discovered not to conform to the description and quality aforesaid or not giving satisfactory performance or have deteriorated, the decision of the purchaser in that behalf shall be final and binding on the supplier and the purchaser shall be entitled to call upon the supplier to rectify the goods/stores/articles or such portion thereof as is found to be defective by the purchaser within a reasonable period or such specified period as may be allowed by the purchaser in his discretion on/an application made thereof by the supplier and in such an event, the above mentioned warranty period shall apply to the goods/stores/ articles rectified from the date of rectification thereof. In case of failure of the supplier to rectify or replace the goods etc., within specified time, the purchaser shall be entitled to recover the cost with all expenses from the supplier for such defective stores.

#### **34. Duties & Taxes**

- a) **GST:** Tenderers should indicate whether the prices quoted are inclusive of GST or other tax ( if applicable). They should indicate the rate (s) of GST or other Tax (as may be applicable)
- b) As the tenderers are requested to quote their prices on F.O.R. destination, door delivery basis.

#### **35. TENDERERS ARE REQUESTED TO QUOTE THEIR RATES ON F.O.R DESTINATION BASIS (Free delivery to Central Store of SVPUA&T, Meerut.**

The decision of the University shall be final as to the quality of the stores and shall be binding upon the tenderers and in case of any of the articles supplied not being found as per specification shall be liable to be rejected or replaced and any expenses or losses caused to the suppliers shall be borne by the supplier. It will be the responsibility of the supplier to ensure that articles supplied are of the best quality and free from all defects. The items/articles supplied will not be more than months (Three months) old. The acceptance of articles will be given only when the articles are found up to the specifications given in the tender enquiry and free from all defects. The rejected items must be removed by the tenderers from the consignee premises within 03 days from the date of the information about their rejection. The in-charge stores concerned will take reasonable view of such materials but in no case shall be responsible for any loss, shortage, damage that may occur to it while it is in the premises of the consignee.

Item-wise price should be quoted. In case of bundled price, the offer shall be summarily rejected.

**Signatures of the bidders**

Performa for client list

S. No.	Equipment Name with make and model No.	Name and Add of Institute in which equipment is in use/ Installed	Authorized Contact Person	Mobile No and e-mail	Year of Installation



**SARDAR VALLABHBHAI PATEL UNIVERSITY OF AGRICULTURE &  
TECHNOLOGY MEERUT-250110**

**Mandate form for e-Payment**

1	Name of the Firm, Company/Institute/Person	
2	Address	
3	Email ID	
4	Contact Number	
5	PAN Number	
6	GST Number	
7	Account Number	
8	Account Type	Saving/ Current
9	IFSC Code (11 Digit)	
10	Name of the Bank	
11	Branch Address and City	
12	Branch Code	

**DECLARATION**

I hereby declare that the particulars given above are correct and complete. If any transaction delayed and not effected for reasons of incomplete or incorrect information I shall not hold Comptroller, SVP University of Agriculture & Technology, Meerut responsible. I also undertake to advise any change in the particulars of my account to facilitate updating of records for purpose of credit of amount through NEFT/RTGS transfer.

Place.....

Date.....

Signature of the Firm/Company/Institute/Person

## Memorandum of Agreement

1. This AGREEMENT made on this \_\_\_\_\_ day  
of

\_\_\_\_\_ 2021 between the  
Comptroller , Sardar Vallabhbhai Patel University of Agriculture & Technology Meerut-250110  
(U.P.)of the ONE PART.

And

M/s \_\_\_\_\_ at \_\_\_\_\_

\_\_\_\_\_ (hereinafter referred to as Contractor) of the OTHER  
PART.

### **2. General**

- 2.1.** SVPUA&T or university has aim for Establishment of IISR Model Jaggery Unit at KVK Hastinapur (Meerut) and KVK Muzaffarnagar-II
- 2.2.** This MoA is for establishment of IISR model jaggery unit.
- 2.3.** The agreement can be terminated if there is any violation of the terms and conditions, quality etc. as may be determined by the SVPUA&T or university.
- 2.4.** The intellectual property right shall be with the SVPUA&T or university.
- 2.5.** During operation of the agreement, if in the opinion of both the parties some alteration or modification of the MoA is considered essential, these may be mutually discussed and agreed upon in writing.
- 2.6.** Both parties on one part and manufacturer on the other part shall be jointly responsible for Establishment of IISR Model Jaggery Unit at KVK Hastinapur (Meerut) and KVK Muzaffarnagar-II
- 2.7.** This MoA is valid for one years from the date of commencement.

### **3. Responsibilities of University and Firm**

The specific responsibilities of the SVPUA&T or university and the firm shall be as follows:

#### **3.1. Responsibilities of SVPUA&T or university**

1. The SVPUA&T or university shall be responsible for facilitating the manufacture for providing related information for Establishment of IISR Model Jaggery Unit at KVK Hastinapur (Meerut) and KVK Muzaffarnagar-II
2. SVPUA&T or university shall, as part of this MoA, nominate a scientist or a group of scientists to work on the project.

#### **3.2. Responsibilities of Awardee firm**

1. Awardee firm shall be responsible for taking care of all technical help and technology for establishment of IISR model jaggery unit.



2. SVPUA&T or university shall as a part of this MoA, nominate a technical officer to work in the project.
3. SVPUA&T or university shall be responsible for providing drawings, list of equipments, and list of manufacturers.
4. The responsibility of firm shall include following the same procedure and instruction as advised by the SVPUA&T or university regarding the technology for the same results. SVPUA&T or university bears no responsibility, if manufacturer does not follow the given instructions. Apart from this, the manufacturer shall also actively associate with activities such as hygiene, value addition etc. They shall also participate in assessment of the technology.

**5. Liabilities**

1. SVPUA&T or university its representative shall not be liable for any loss and damage of any kind during the execution period.

**6. Disputes**

- 1 Any dispute arising during operation of the MoA shall be settled through mutual consultations and agreement. However, the final decision of SVPUA&T or university shall be binding.
- 2 In case of any legal dispute, the legal jurisdiction shall be court of law at Meerut (UP), India.

Counter Signed by : Director Extension or competent authority

**Witness:**

Signature  
Name  
Designation  
Address

Signature  
Name  
Designation  
Address